

# Predictive Control of Redundant Manipulators based on Avoidance Manipulability

Yang Hou ( Okayama Univ. ) Akira Yanou ( Okayama Univ. ) Mamoru Minami ( Okayama Univ. )  
Yosuke Kobayashi ( Okayama Univ. ) Satoshi Okazaki ( Okayama Univ. )

Yang Hou, Okayama University, houyang@suri.sys.okayama-u.ac.jp  
Akira Yanou, Okayama University, yanou@suri.sys.okayama-u.ac.jp  
Mamoru Minami, Okayama University, minami@suri.sys.okayama-u.ac.jp  
Yosuke Kobayashi, Okayama University, kobayashi2@suri.sys.okayama-u.ac.jp  
Satoshi Okazaki, Okayama University, okazakis@suri.sys.okayama-u.ac.jp

This paper proposes a new approach named predictive control of redundant manipulators based on avoidance manipulability to achieve an on-line control of trajectory tracking and obstacle avoidance for redundant manipulators. In the trajectory tracking process, manipulator is required to keep a configuration with maximal avoidance manipulability in real time. Predictive control in this paper uses manipulators' future configurations to control current configuration aiming at completing tasks of trajectory tracking and obstacle avoidance on-line and simultaneously with higher avoidance manipulability. We compare Multi-Preview Control with predictive control using redundant manipulator, and show the results through simulations.

**Key Words:** AMSIP, Multi-Preview Control, Predictive Control

## 1. INTRODUCTION

Over the past two decades, redundant manipulators were used for various tasks, for example, welding, sealing and grinding. These kinds of tasks require that the manipulator plan its hand onto a desired trajectory (trajectory tracking) and avoid its intermediate links, meaning all comprising links of robot except the top link with the end-effector, from obstacles existing near the target object and also the target object itself (obstacle avoidance).

There are many researches on the motion of redundant manipulators discussing how to use the redundancy. The proposed solutions to this problem can be broadly categorized into two classes: Global Methods and Local Methods. Global Methods<sup>[1],[2]</sup> solve the collision avoidance problem by an entire path planning which is only suited for structured and static environment. Moreover, the computational cost of Global Methods is expensive and usually increases exponentially along with the number of manipulator's joints. On the other hand, Local Methods<sup>[3],[4]</sup> solve the collision avoidance problem in unstructured and dynamic environment. Local Method's system has the ability to be flexible even in surroundings with limited information. The information of the environment used in Local Method is naturally restricted to perform the tasks on-line in limited recognition time.

The future information required for path planning can be available to use for Local Method, then it should be possible that the real-time configuration control in Local Method may approach the configuration behavior of Global Method. We had connected the concepts of Local Method and Global Method by introduced a concept of Multi-Preview Control strategy. We had also proposed adaptive system using Local Method. The features of our system are shown in Fig.1 where the camera scene area symbolizes the restricted information of environment. In Fig.1, the camera and the manipulator's hand are supposed to move synchronously to achieve on-line operation depending on the real-time restricted information. When the camera detects a new obstacle appearing suddenly in the scene, the manipulator must change its configuration immediately to avoid

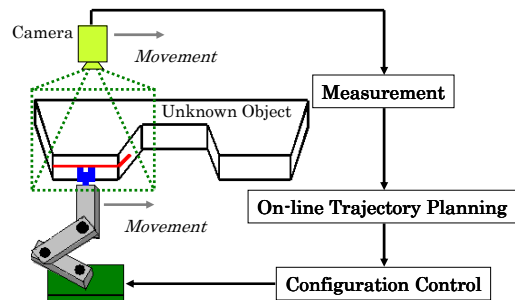

Fig. 1 Processing system for unknown object

it. We have to measure the shape of working object before starting task to complete path-planning using Global Methods, so we have to predetermine the shape of manipulator that does not collide from the start to goal of the hand's task, and the manipulator traces the shape successively to complete the task. Multi-Preview Control can refer to many shapes of manipulator optimized by avoidance manipulability to induce the current manipulator's shape<sup>[5]</sup>, and avoid collisions with the obstacles. However, because Multi-Preview Control can not immediately compensate the error when manipulator is tracking trajectory or avoiding obstacle, there are still existing possible situations that manipulator could not avoid collision effectually. Moreover in actual working situation, oscillation or overshoot on the tracking trajectory of manipulator's hand may occur because manipulator has dynamics.

For these problems, the prediction of manipulator's future configuration has possibility of effectively compensating a tracking error. In other words, predictive control of redundant manipulator considering avoidance manipulability may realize fast and precision working. Therefore this paper deals with fundamental research on the prediction of future configuration of redundant manipulator based on Multi-Preview Control, and discusses its effectiveness by comparison to Multi-Preview Control through simulations.

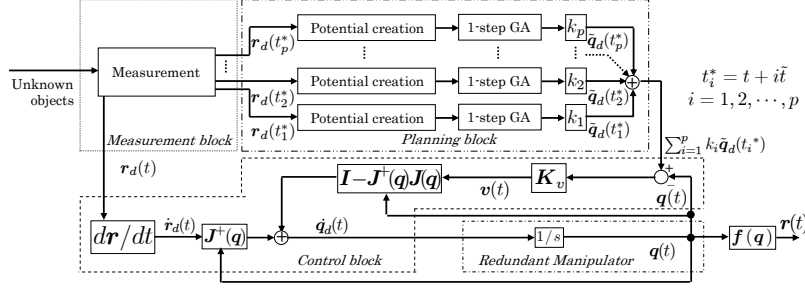

Fig. 2 Multi-Preview Control system

## 2. AVOIDANCE MANIPULABILITY SHAPE INDEX WITH POTENTIAL

We proposed Avoidance Manipulability Ellipsoid and Avoidance Manipulability Shape Index (AMSI) in [5], and Avoidance Manipulability Shape Index with Potential (AMSIP) in [6]. Avoidance Manipulability Ellipsoid is applied from Manipulability Ellipsoid proposed by Prof. Yoshikawa in [7]. We will elucidate them briefly in this section.

When the desired hand velocity  $\dot{r}_{nd}$  is given,  $\dot{q}_n$  is solved as

$$\dot{q}_n = \mathbf{J}_n^+ \dot{r}_{nd} + (\mathbf{I}_n - \mathbf{J}_n^+ \mathbf{J}_n) \mathbf{l}, \quad (1)$$

where  $\mathbf{J}_n^+$  is the pseudo-inverse of Jacobean Matrix  $\mathbf{J}_n$  and  $\mathbf{I}_n$  is a  $n \times n$  unit matrix. In addition,  $\mathbf{l}$  is an arbitrary vector. Trajectory tracking of the hand and collision avoidance can be executed simultaneously through this vector  $\mathbf{l}$ . Here, control variable  $\mathbf{l}$  is determined so as to make actual manipulator's shape at current time  $\mathbf{q}(t)$  close to future optimal shape by referring to the future optimal shapes of imaginary manipulators. The relation of the desired velocity of the  $i$ -th link  ${}^1\dot{r}_{id}$  and the desired hand velocity  $\dot{r}_{nd}$  is shown in Eq.(2).

$${}^1\dot{r}_{id} = \mathbf{J}_i \mathbf{J}_n^+ \dot{r}_{nd} + \mathbf{J}_i (\mathbf{I}_n - \mathbf{J}_n^+ \mathbf{J}_n) \mathbf{l} \quad (2)$$

Here we define two variables shown in Eq.(3) and Eq.(4).

$$\Delta^1 \dot{r}_{id} \triangleq {}^1\dot{r}_{id} - \mathbf{J}_i \mathbf{J}_n^+ \dot{r}_{nd}, \quad (3)$$

$${}^1\mathbf{M}_i \triangleq \mathbf{J}_i (\mathbf{I}_n - \mathbf{J}_n^+ \mathbf{J}_n). \quad (4)$$

According to Eq.(2), Eq.(3) and Eq.(4),  $\Delta^1 \dot{r}_{id}$  can be rewritten as

$$\Delta^1 \dot{r}_{id} = {}^1\mathbf{M}_i \mathbf{l}. \quad (5)$$

In Eq.(5),  $\Delta^1 \dot{r}_{id}$  is called the first avoidance velocity and  ${}^1\mathbf{M}_i$  is a  $m \times n$  matrix called the first avoidance matrix.

Next, we will represent the Avoidance Manipulability Ellipsoid. Providing that  $\mathbf{l}$  is restricted as  $\|\mathbf{l}\| \leq 1$ , then the extent where  $\Delta^1 \dot{r}_{id}$  can move is denoted as

$$\Delta^1 \dot{r}_{id}^T ({}^1\mathbf{M}_i^+)^T {}^1\mathbf{M}_i^+ \Delta^1 \dot{r}_{id} \leq 1. \quad (6)$$

If  $\text{rank}({}^1\mathbf{M}_i) = m$ , the ellipsoid represented by Eq.(6) is named as the first complete avoidance manipulability ellipsoid. If  $\text{rank}({}^1\mathbf{M}_i) = p < m$ , the ellipsoid is named as the first partial avoidance manipulability ellipsoid.

The volume of each Avoidance Manipulability Ellipsoid indicates mobility of each link (shape-changeability). The larger total volume indicates the higher whole avoidance manipulability. We evaluated total volume as Avoidance Manipulability Shape Index

(AMSI). Then we proposed Avoidance Manipulability Shape Index with Potential (AMSIP) which considers AMSI and the distance between the manipulator and target object. And we verified the superiority of AMSIP through the simulation in [6].

## 3. MULTI-PREVIEW CONTROL

Multi-Preview Control controls current manipulator's shape by referring several imaginary manipulator's shape at several future times. We assume three imaginary manipulators are used for referring so as to make it easy to explain the effectiveness clearly. Multi-Preview Control System is shown in Fig.2 which is a configuration control method to change current manipulator's shape satisfying non-collision requirement by referring to the future configurations based on an on-line measurement. It consists of an on-line measurement block, a path planning block, a redundancy control block and redundant manipulator. On the assumption that current time is represented by  $t$ , and the future times are defined as  $t_i^* = t + i\tilde{t}$ , ( $i \in [1, p]$ ) where  $\tilde{t}$  denotes preview time and  $i$  is the number of future times. A measurement block detects a desirable hand position  $\mathbf{r}_d(t_i^*)$  on the surface of the target object at time  $t_i^*$ , which is reasonably assumed to be possible to detect the future information only in the detected camera image in Fig.1. Firstly, potential space based on the detected shape of the target object is created around it at the path planning block. Then the path planning block outputs the optimal shape  $\tilde{q}_d(t_i^*)$  corresponding to the maximum  ${}^1S$  presented in [5] at the future time  $t_i^*$  (imaginary manipulator) by 1-Step GA. The control block outputs desired joint angular velocity  $\dot{q}_d(t)$  that makes actual manipulator's shape at current time  $\mathbf{q}(t)$  close to the optimal shape in the future by referring to  $\sum_{i=1}^p \tilde{q}_d(t_i^*)$ .

An equation which realizes this control system is named as Preview Control equation and expressed as follows

$$\dot{q}_d = \mathbf{J}_n^+ \dot{r}_{nd} + (\mathbf{I}_n - \mathbf{J}_n^+ \mathbf{J}_n) \mathbf{l}(t). \quad (7)$$

where  $n \times 1$  matrix  $\mathbf{l}(t)$  is defined as

$$\mathbf{l}(t) = \mathbf{K}_v \left( \sum_{i=1}^p \tilde{q}_d(t_i^*) - \mathbf{q}(t) \right) = \begin{bmatrix} \sum_{i=1}^p \tilde{q}_{1d}(t_i^*) - q_1(t) \\ \vdots \\ \sum_{i=1}^p \tilde{q}_{jd}(t_i^*) - q_j(t) \\ 0 \\ \vdots \\ 0 \end{bmatrix}, \quad (8)$$

when redundant degrees  $j$  remains and the redundancy is used for the joints from 1 to  $j$ .

## 4. PREDICTIVE CONTROL METHOD

We used predictive value of manipulator's configuration in preview control equation. In order to make the actual manipulator's posture be closer to the future configuration of imaginary manipulator, we changed the  $l(t)$  of the second part of Multi-preview's control equation as follow.

$$l(t) = \mathbf{K}_v \sum_{i=1}^p k_i \left( \hat{\mathbf{q}}_d(t_i^*) - \hat{\mathbf{q}}(t_i^*) \right) \quad (9)$$

We thought that the  $\hat{\mathbf{q}}(t_i^*)$  is the future configuration's predictive value of manipulator. And in our research, we gave the following Eq.(10) because we define  $t_i^* = t + i \cdot \tilde{t}$  in the previous section.

$$\mathbf{q}(t_i^*) = \mathbf{q}(t + i \cdot \tilde{t}), (i = 1, 2, \dots, p) \quad (10)$$

After using Taylor expansion to calculate the predictive value  $\hat{\mathbf{q}}(t_i^*)$ , then following equation Eq.(11), which is first approximation of Taylor expansion, could be derived,

$$\mathbf{q}(t + i \cdot \tilde{t}) \approx \mathbf{q}(t) + i \cdot \tilde{t} \dot{\mathbf{q}}(t) \quad (11)$$

To the differential part in Eq.(11), we did approximate calculation by using Eq.(12).

$$\dot{\mathbf{q}}(t) \approx \frac{\mathbf{q}(t) - \mathbf{q}(t - h)}{h} \quad (12)$$

Where  $h$  is a tiny value. Based on the above equations, we did first approximate calculation to the Taylor expansion for manipulators' future configuration value, and after replacing the differential term of Eq.(11) to Eq.(12), we can derive the predictive equation  $\hat{\mathbf{q}}(t_i^*)$  of actual manipulators' configuration as follow.

$$\hat{\mathbf{q}}(t_i^*) = \left( 1 + \frac{i \cdot \tilde{t}}{h} \right) \mathbf{q}(t) - \frac{i \cdot \tilde{t}}{h} \mathbf{q}(t - h) \quad (13)$$

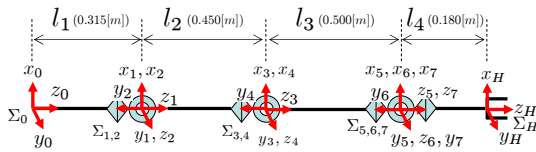

Fig. 3 Structure of PA10

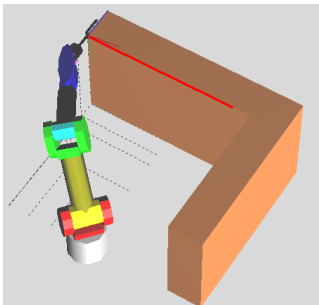

Fig. 4 Outside appearance of simulation

## 5. SIMULATION

In order to compare the Multi-Preview Control with predictive control, we use a 7-link manipulator for simulations, which is produced by Mitsubishi Heavy Industries named PA10 and the structure of PA10 is shown in Fig.3. Hand tracking trajectory and given manipulator's shape are depicted in Fig.4, target hand trajectory is predefined. In addition, the kinematics of PA10 is implemented in the simulator. The solid line in Fig.4 expresses a target trajectory set to be followed. The simulation's screen shot is shown in Fig.5.

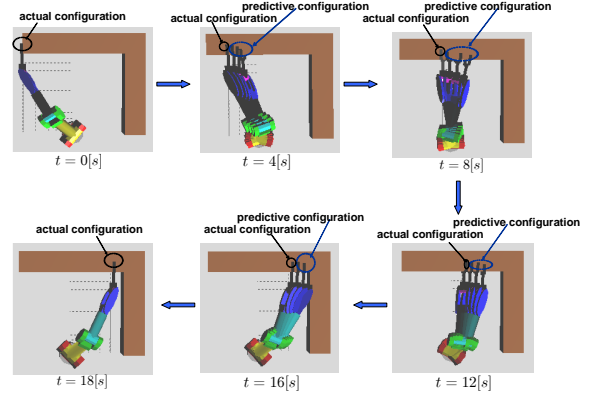

Fig. 5 Screen shot of simulation

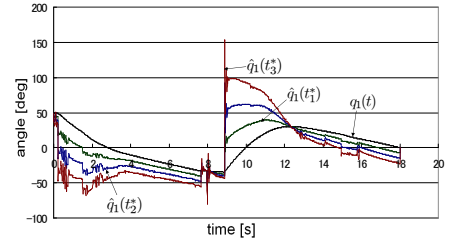

Fig. 6 Actual and predictive angle of link 1

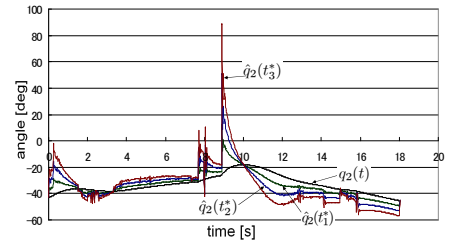

Fig. 7 Actual and predictive angle of link 2

The angle of actual manipulators' link 1 and the predictive angles  $\hat{q}_1(t_1^*)$ ,  $\hat{q}_1(t_2^*)$ ,  $\hat{q}_1(t_3^*)$  of manipulators' link 1 are respectively indicated in Fig.6. Similarly, the angle of actual manipulators' link 2 and the predictive angles  $\hat{q}_2(t_1^*)$ ,  $\hat{q}_2(t_2^*)$ ,  $\hat{q}_2(t_3^*)$  of it are respectively indicated in Fig.7. Moreover, we use Runge Kutta method to calculate current angle of actual manipulator in simulation, the interval time  $h$  of Runge Kutta is 0.03 [s], and the value  $h$  also be used in Eq.(13). In addition, the predictive interval time  $\tilde{t}$  of  $\hat{\mathbf{q}}(t_i^*)$  is 1.2 [s] and also the same as preview time in Multi-Preview Control, by the other word,  $\hat{\mathbf{q}}(t_1^*)$ ,  $\hat{\mathbf{q}}(t_2^*)$  and  $\hat{\mathbf{q}}(t_3^*)$  express the predictions of future configurations  $\mathbf{q}(t + 1.2)$ ,  $\mathbf{q}(t + 2.4)$  and  $\mathbf{q}(t + 3.6)$  at  $t$  respectively.

After analyzed Fig.6 and Fig.7, we considered that the angle of actual manipulator is changing according to predictive value.

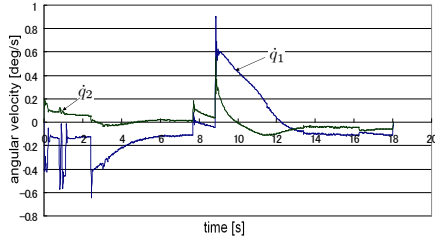

Fig. 8 Angular velocity of link 1 and link 2

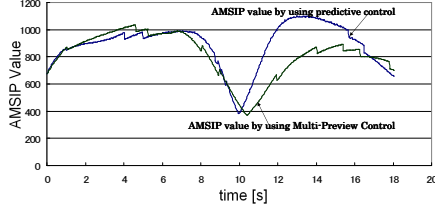

Fig. 9 AMSIP value

For example, in Fig.6, the angle of actual manipulators' link 1 at  $t=12[s]$  has three predictive value  $\hat{q}_1(t_1^*)$ ,  $\hat{q}_1(t_2^*)$ ,  $\hat{q}_1(t_3^*)$  equal to 33.8[deg], 38.0[deg], 42.2[deg] and the actual angle approximates to 29.7[deg], when  $t=13.2[s]$ , actual angle approximates to 27.9[deg]. The angle of actual manipulators' link 1 has three predictive value  $\hat{q}_1(t_1^*)$ ,  $\hat{q}_1(t_2^*)$ ,  $\hat{q}_1(t_3^*)$  equal to 22.9[deg], 17.9[deg], 12.9[deg] at  $t=13.2[s]$ , when  $t=14.4[s]$ , actual angle approximates to 22.0[deg]. Similarly the angle of actual manipulators's link 1 has three predictive value  $\hat{q}_1(t_1^*)$ ,  $\hat{q}_1(t_2^*)$ ,  $\hat{q}_1(t_3^*)$  equal to 16.0[deg], 10.1[deg], 4.2[deg] at  $t=14.4[s]$ , when  $t=15.6[s]$ , actual angle approximate to 14.4[deg]. Obviously, the posture of manipulator could be closer to the future configuration expressed by predictive values. We thought that actual manipulators' posture could be forecasted effectively by using predictive control.

But in Fig.6 and Fig.7, we found that predictive values increased suddenly with high speed at  $t=9$ , and reason of the problem could be explained by Fig.8. In Fig.8 we could understand that values of angular velocity of link 1 and link 2 changed to two big values when  $t=9$ , because of the predictive Eq.(13) based on equation Eq.(12) which can also to be known as calculating angular velocity. So the problem of predictive values changing suddenly could be interpreted.

Furthermore, we got the AMSIP average of actual manipulator's posture by using Multi-Preview Control and predictive control by fifteen times respectively, and indicated the average values by time  $t$  in Fig.9. Compared with Multi-Preview Control, we believe that AMSIP value can maintain a higher value by using predictive control. Through simulations, we thought predictive control has a possibility to be superior to Multi-Preview Control.

Finally, we investigated the manipulability degree  $\omega(\mathbf{q}(t))$  of actual angles  $\mathbf{q}(t)$  and the predictive angles  $\hat{\mathbf{q}}(t_1^*)$ ,  $\hat{\mathbf{q}}(t_2^*)$ ,  $\hat{\mathbf{q}}(t_3^*)$  of manipulators based on Eq.(14), and showed the result by Fig.10.

$$\omega(\mathbf{q}(t)) = \sqrt{\det \mathbf{J}_n(\mathbf{q}(t)) \mathbf{J}_n^T(\mathbf{q}(t))} \quad (14)$$

Observed Fig.10, we obviously can believe that predictive control can also predict the manipulability degree of manipulator. However, when  $t=9$  the value of manipulability degree get large suddenly, and manipulability degree become difficult to be predicted. About this problem, we also need to do further study.

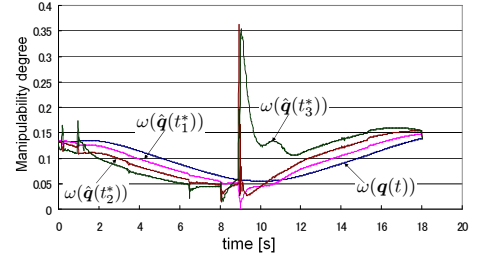

Fig. 10 Manipulability degree

## 6. CONCLUSION

In this paper, we propose predictive control that is improved and modified from Multi-Preview Control to solve a on-line trajectory tracking and obstacle avoidance problem for redundant manipulator. We verify the validity of predictive control through simulations of comparing it with Multi-Preview Control. By using predictive control, the manipulator's shape changes early to avoid collision with working object, and completes desired hand task in more secure situation because of higher AMSIP value existed. From simulation results we have proved the effectiveness of applying predictive control to Multi-Preview Control. However, sometimes predict outcome cannot continue to derive desired state because predictive values sometimes are too large as shown in simulation when we use the predictive control. Hence the next step of our research is to consider these issues seriously and find the way to resolved them successfully.

## REFERENCES

- [1] Rodrigo S. Jamisola, Jr. Anthony A. Maciejewski, Rodney G. Roberts "Failure-Tolerant Path Planning for Kinematically Redundant Manipulators Anticipating Locked-Joint Failures", IEEE Transactions on Robotics, Vol.22, No.4, 2006, pp.603-612.
- [2] Juan Manuel Ahuactzin, Kamal K. Gupta "The Kinematic Roadmap: A Motion Planning Based Global Approach for Inverse Kinematics of Redundant Robots", IEEE Transactions on Robotics and Automation, Vol.15, No.4, 1999, pp.653-669.
- [3] Leon Zlajpah, Bojan Nemec, "Kinematic Control Algorithms for On-line Obstacle Avoidance for Redundant Manipulator", International Conference on Intelligent Robots and Systems, 2002, pp.1898-1903.
- [4] Homayoun Seraji, Bruce Bon, "Real-Time Collision Avoidance for Position-Controlled Manipulators", IEEE Transactions on Robotics and Automation, Vol.15, No.4, 1999, pp.670-677.
- [5] Hiroshi Tanaka, Mamoru Minami and Yasushi Mae, "Trajectory Tracking of Redundant Manipulators Based on Avoidance Manipulability Shape Index ", International Conference on Intelligent Robots and Systems, Edmonton, 2005, pp.1892-1897.
- [6] Keiji Ikeda, Hiroshi Tanaka, Tongxiao Zhang, Mamoru Minami, Yasushi Mae, "On-line Optimization of Avoidance Ability for Redundant Manipulator", International Conference on Intelligent Robots and Systems, Beijing, 2006, pp.592-597.
- [7] Tsuneo Yoshikawa, "Foundations of Robot Control ", CORONA PUBLISHING CO., LTD.,1988